



Coord3 DCC CMM

Model : KRONOS

The KRONOS by Coord3 is a high precision, large CMM that is perfect for your larger inspection needs. This machine is capable of measuring high precision prismatic elements, gauging/testing complex shapes, surface checks, point to point inspection and scanning with contact and optical sensors. Multiple machine travel lengths are available!

- | | | |
|----|--------------|---------------|
| 1. | Style : | DCC |
| 2. | Probe : | PH10 |
| 3. | Controller : | Renishaw UCC2 |
| 4. | Software : | CAPPS-DMIS |
| 5. | Frame Type : | Bridge |
| 6. | Resolution : | 4.0 um |

Machine Dimensions

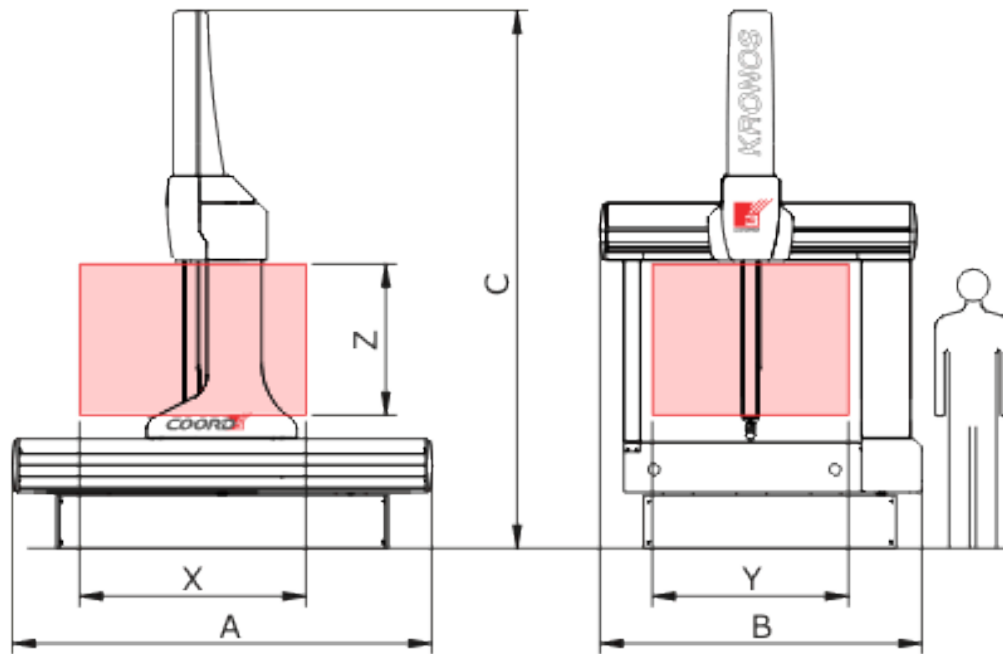

KRONOS Model	Strokes (mm)			Overall dimensions (mm)		
	X	Y	Z	A	B	C
15-13-10	1500	1300	1000	2830	2132	3559
20-13-10	2000	1300	1000	3330	2132	3559
25-13-10	2500	1300	1000	3830	2132	3559
30-13-10	3000	1300	1000	4330	2132	3559
15-15-13	1500	1500	1300	2830	2332	4159
20-15-13	2000	1500	1300	3330	2332	4159
25-15-13	2500	1500	1300	3830	2332	4159
30-15-13	3000	1500	1300	4330	2332	4159



Technical Specifications

STRUCTURE

Coordinate Measuring Machine, CNC type, with mobile bridge structure on granite table machine base.

Guideways:

X axis: dovetail guideways machine into the granite table.

Y/Z axis: micromachined anodized light alloy extrusion.

Drive Method:

X axis: zero hysteresis friction drive, rack & pinion

Y axis: zero hysteresis friction drive

Z axis: zero hysteresis friction drive

Sliding System:

Air bearings on all axes

Motion Control:

DC servomotor on all axes

Thermal Compensation:

Multi-sensors temperature compensation system for part and scale. (by request)

Measuring System:

PROBING SYSTEM

Manual Probe Head:

MIH, MH20, MH20i, RTP20

Motorized Probe Head:

PH10T, PH10M, PH10MQ

Point-to-Point Trigger Probe:

TP2, TP20, TP200

Analog Contact Probe:

SP25

Laser Probe:

Metris LC/XC series (qualification sphere included)

Stylus and Probe Changer:

Fully automated stylus and probe changers

CONTROL UNIT

Terminal Unit is used by the operator to manually control the motorized measuring machine (ArKey)
The controller feature the continuous interpolation of axes motion for cycle time optimization

Optional

-Index/continuous Rotary Table

ENVIRONMENT

Temperature Range for Metrological Specification:

Max. gradient per hour: 1.5 *C/h

Max. gradient per day: 2.0 *C/24h

Max. gradient in space: 0.5 *C/m

Acceptable Vibrations:

(vibration acceleration between peaks)

30mm/s from 1 to 10 Hz

15mm/s from 10 to 20 Hz

50mm/s from 20 to 100 Hz

AIR SUPPLY

Air Consumption:

160 NI/min

Minimum Air Supply:

6 Bar (79psi)

POWER SUPPLY

Power Supply Voltage:

230 V +/- 10%; 50 Hz +/- 2% (single phase)

Maximum Power Consumption:

10A 1600 W

OPTIONS

Passive vibration insulating system

Active vibration insulation system (AVM)

Multi-wire Cable

Loading/unloading pallet system, manual or automatic

PC & Printer

Training

Installation

WARRANTY

12 months from the date of acceptance test or a maximum of 15 months from date of shipment

CAPPS Powerfully Simple

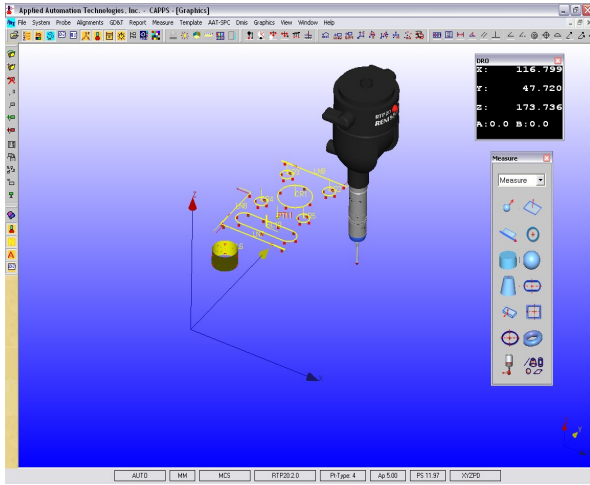

Capps Powerfully Simple is the least expensive measurement software with complete geometrical measuring capabilities.

- Complete measurement and GD&T
- Complete construction Methods
- Easy alignment and calibration
- Easy to learn 3D graphics menus and toolbars
- Measurements displayed in 3D
- Easy CAD like 3D graphics with user interaction
- Flexible reporting options with spread sheet like editing
- Scalable digital readout
- DMIS input/output options
- Easy upgrade to Basic Plus or Advanced

CAPPS Basic Plus

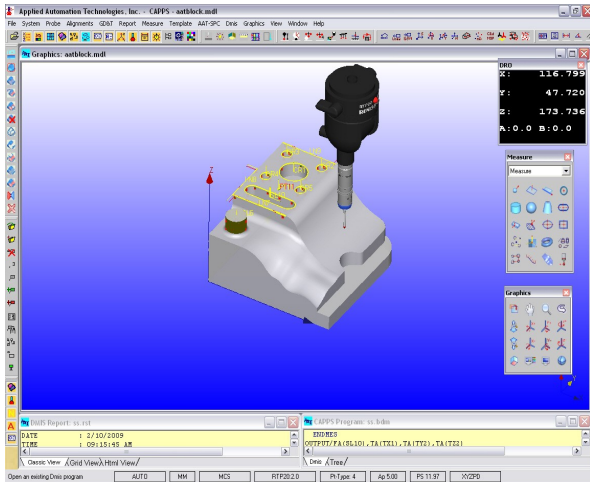

Capps Basic Plus is a complete measurement software with CAD capability for geometrical features.

- Native DMIS programming
- Automatic Probe Calibrations
- MGP CAD alignment macros
- Import and display CAD models with wireframe elements
- Extraction of Nominals from wireframe or create from blue prints
- Adaptive curve scanning
- Reverse engineering to CAD
- Easy upgrade to CAPPS-DMIS Advanced

CAPPS Advanced

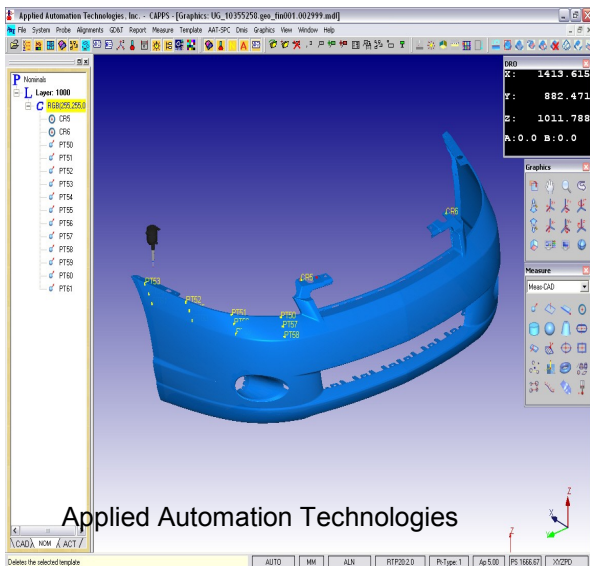

Capps Advanced is a CAD based metrology software with easy to use graphics. Complete control over mathematical model, easy and precise alignment methods, automatic feature measurements and geometry recognition. Parts can be measured with or without CAD models automatically creating DMIS programs. Features of our Advanced level software include:

- CAD master model at the CMM
- Automatic collision avoidance
- Auto Probe Calibration
- Advanced CAD operations for surface and curve manipulation
- Automatic probe path generation routines for all geometric and