



3D CMM Base

Model : CWB-8106

- | | |
|----------------------|---------------------------------------|
| 1. Travel : | 800 X 1000 X 530 mm (X, Y, Z) |
| 2. Resolution : | Renishaw 0.001mm Linear scales |
| 3. Probe : | PH10T + TP20 |
| 4. Laser Probe : | Conoprobe -1000 + 50mm LENS |
| 5. Transmission : | Air Bearing in 3 Axis |
| 6. Granite Plate : | DIN. 876, 0 grade |
| 7. Machine Weight : | 4620 KGS |
| 8. Drive : | Servo Motors + Joystick |
| 9. Linear Accuracy : | U1 = 2+L / 200um ; U3 = 4 + L / 100um |
| 10. Software : | CAPPS-DMIS |
| 11. Controller : | Deva 004 PCI and Deva 030 Servo Amp |

Machine Dimensions

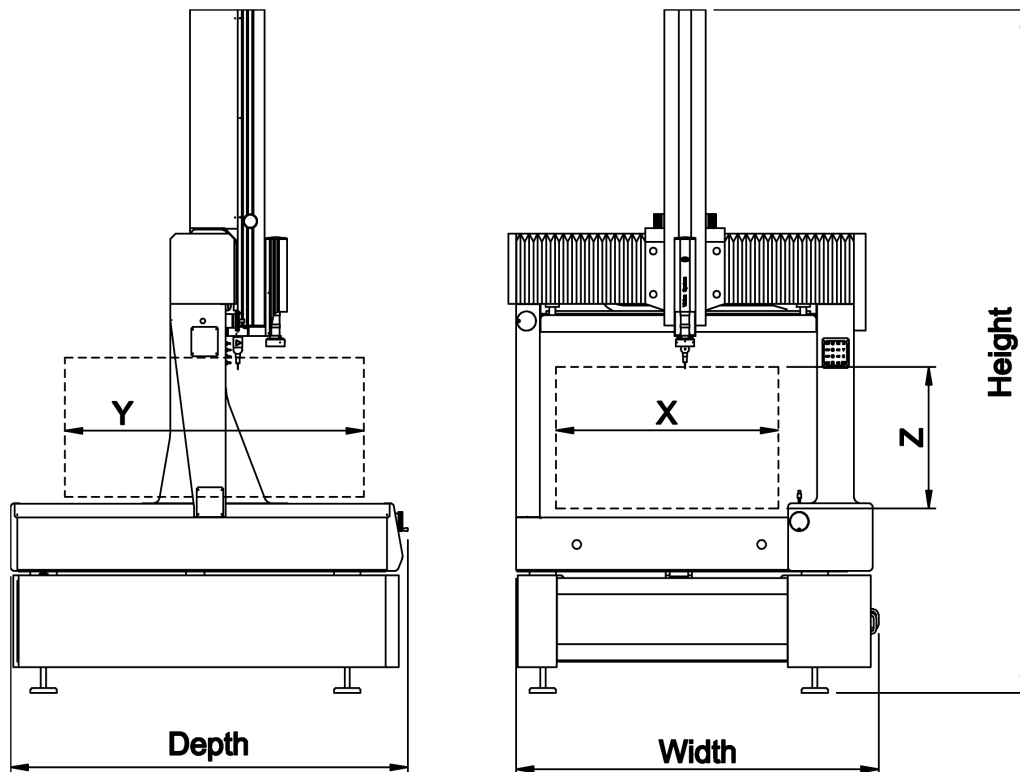

<u>Model</u>	<u>X</u>	<u>Y</u>	<u>Z</u>	<u>HEIGHT</u>	<u>WIDTH</u>	<u>DEPTH</u>
8106A-LV	800	1000	530	1780	2040	3020
8106A-CNC	800	1000	600	1780	2040	3020

CAPPS Powerfully Simple

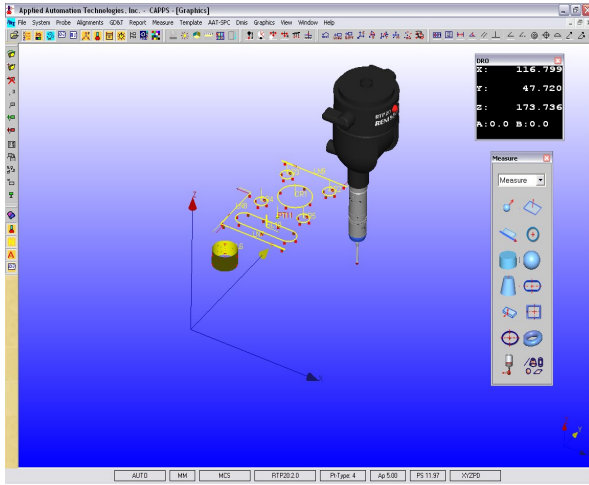

Capps Powerfully Simple is the least expensive measurement software with complete geometrical measuring capabilities.

- Complete measurement and GD&T
- Complete construction Methods
- Easy alignment and calibration
- Easy to learn 3D graphics menus and toolbars
- Measurements displayed in 3D
- Easy CAD like 3D graphics with user interaction
- Flexible reporting options with spread sheet like editing
- Scalable digital readout
- DMIS input/output options
- Easy upgrade to Basic Plus or Advanced

CAPPS Basic Plus

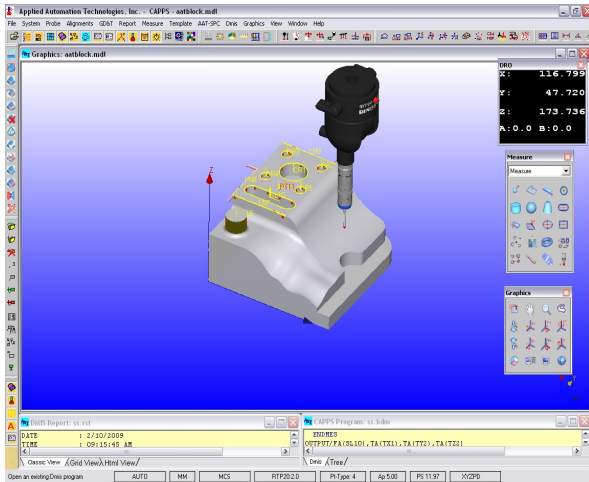

Capps Basic Plus is a complete measurement software with CAD capability for geometrical features.

- Native DMIS programming
- Automatic Probe Calibrations
- MGP CAD alignment macros
- Import and display CAD models with wireframe elements
- Extraction of Nominals from wireframe or create from blue prints
- Adaptive curve scanning
- Reverse engineering to CAD
- Easy upgrade to CAPPS-DMIS Advanced

CAPPS Advanced

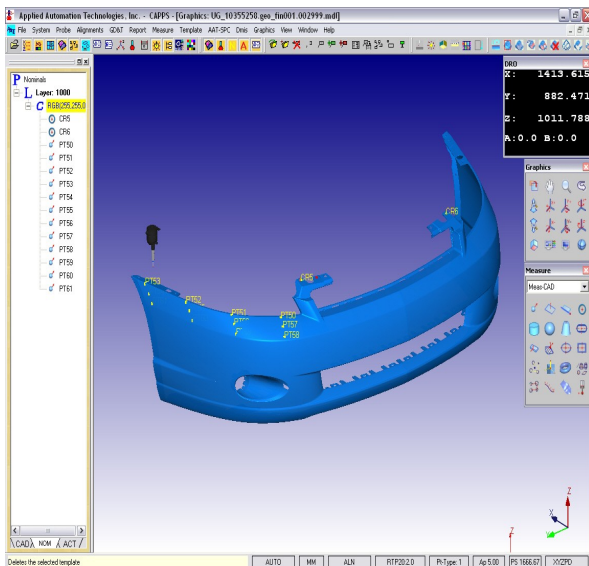

Capps Advanced is a CAD based metrology software with easy to use graphics. Complete control over mathematical model, easy and precise alignment methods, automatic feature measurements and geometry recognition. Parts can be measured with or without CAD models automatically creating DMIS programs. Features of our Advanced level software include:

- CAD master model at the CMM
- Automatic collision avoidance
- Auto Probe Calibration
- Advanced CAD operations for surface and curve manipulation
- Automatic probe path generation routines for all geometric and sheet-metal features
- Automatic feature extraction from a CAD model
- Advanced Fixtureless alignment methods with CAD